

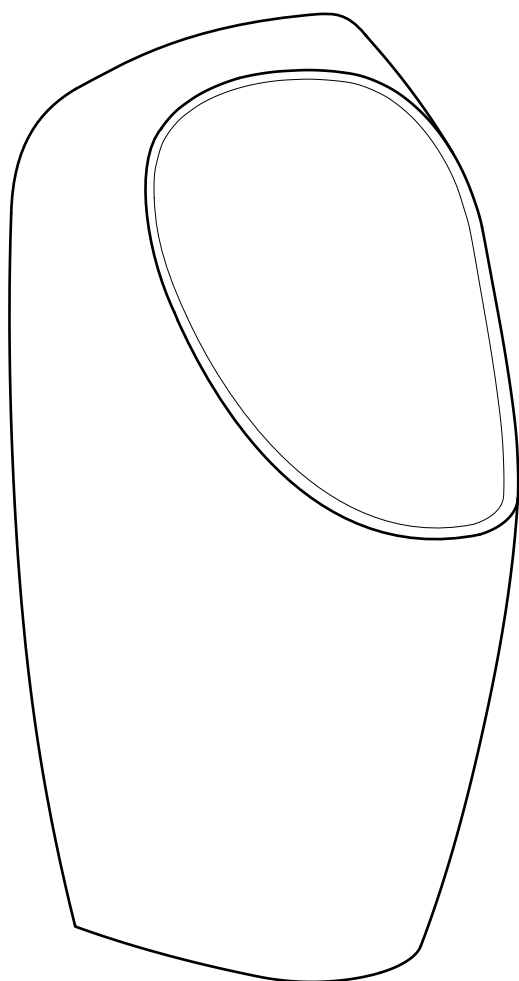

Installation instruction
Installationsanleitung
Instruction de l'installation
Instrucción de instalación
Instrução de instalação
Istruzioni per l'installazione

URIMAT
ceramic compact
Art. 12301



1 x 23.300 / Ceramic Compact

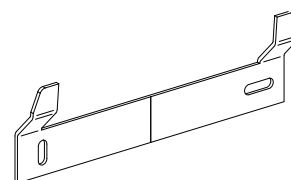

1 x 58.401 / Mounting Bracket



2 x Screw / Washer / Dowel



1 x 56.111 / Screen

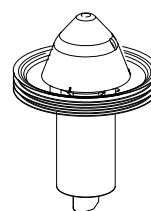

1 x 52201 / MB ActiveTrap

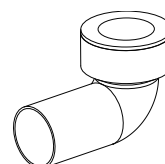

1 x 58.009 / Drainpipe DN50

Dimensioning
Abmasse
Massification

Masificación
Massificação
Massificazione

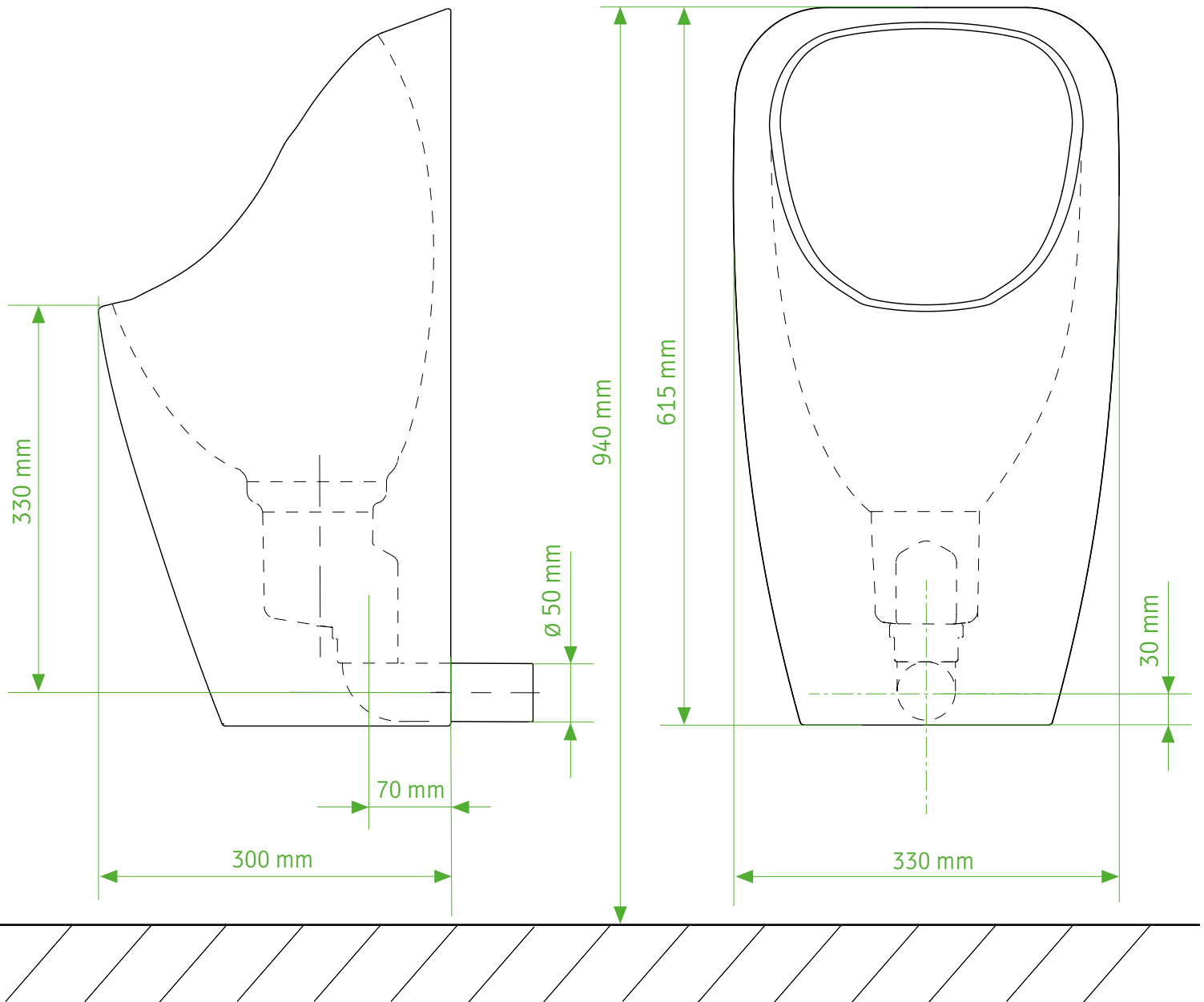

Important:

Make sure all drainpipes are professionally cleaned when replacing existing waterflushed urinals.

Wichtig:

Abwasserleitung müssen vor der Montage der URIMAT Urinale gereinigt werden. Es ist sicherzustellen, dass Uringestein und andere Ablagerungen beseitigt sind.

Important:

Les écoulements d'eau résiduelles doivent être purgé avant le montage de l'urinoir URIMAT. Il faut assure que la pierre d'urine es d'autre dépôt sont éliminé.

Importante:

Asegurese cuando instale los URIMAT que los desagües existentes están perfectamente limpios y totalmente exentos de obturaciones.

Importante:

Ao trocar um Urinol convencional por um URIMAT deverá ser garantida a limpeza da tubagem por pessoal especializado.

Importante:

Assicurrarsi che tutte le grondaie siano pulite professionally in caso di sostituzione orinatoj waterflushed esistenti.

Installation
Montage
Installation

Instalación
Instrução
Installazione

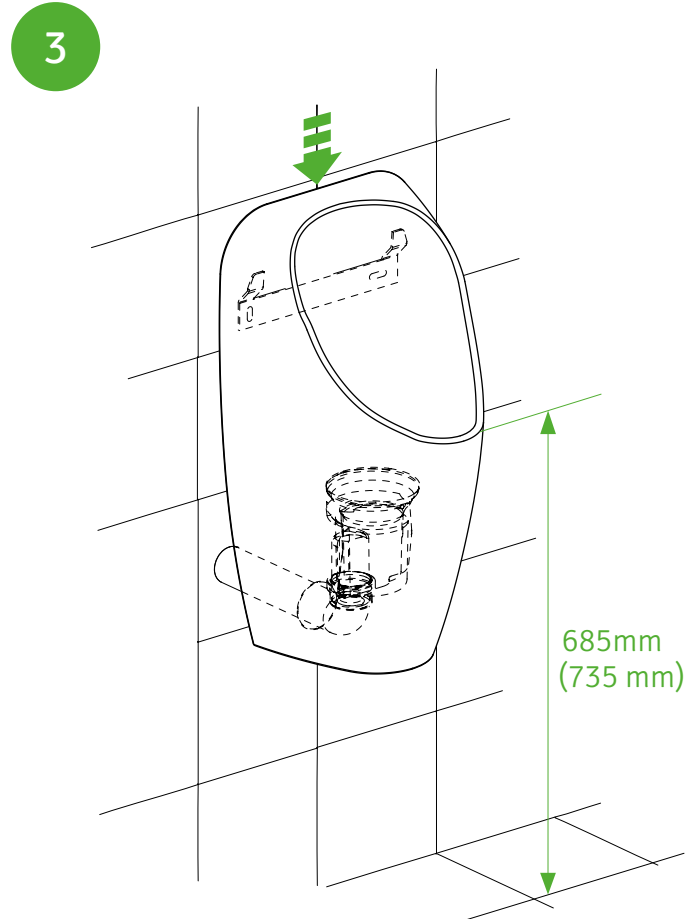
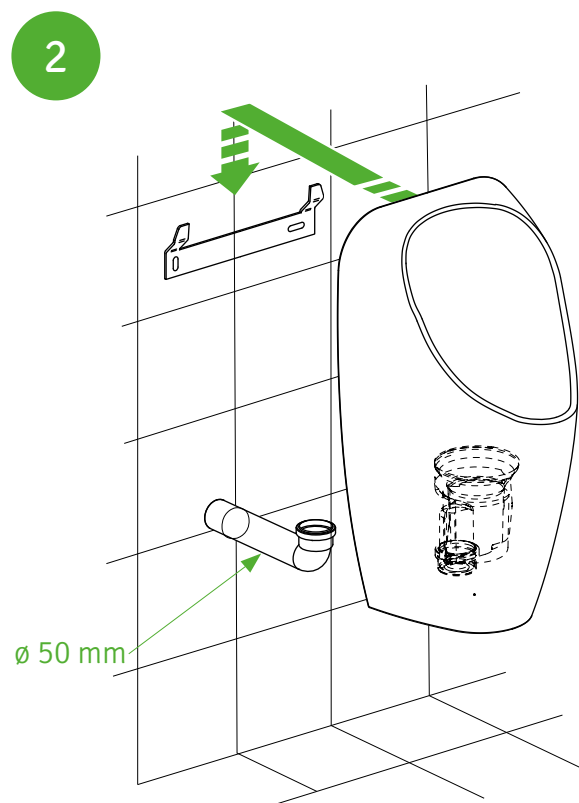
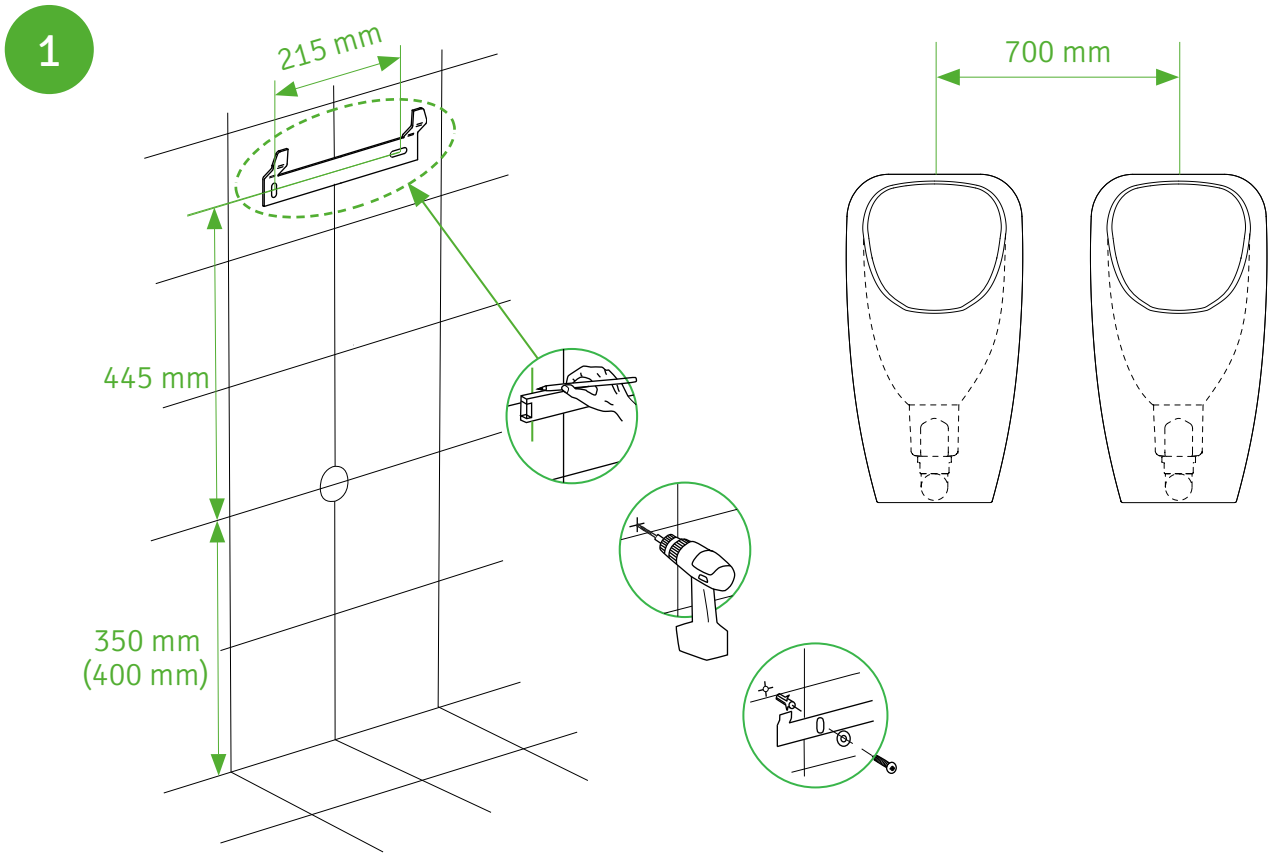



MB-ActiveTrap

Wechsel / Replacement / Scambio
 Cambio / Échange / Câmbio



New



50% used



Change!

