

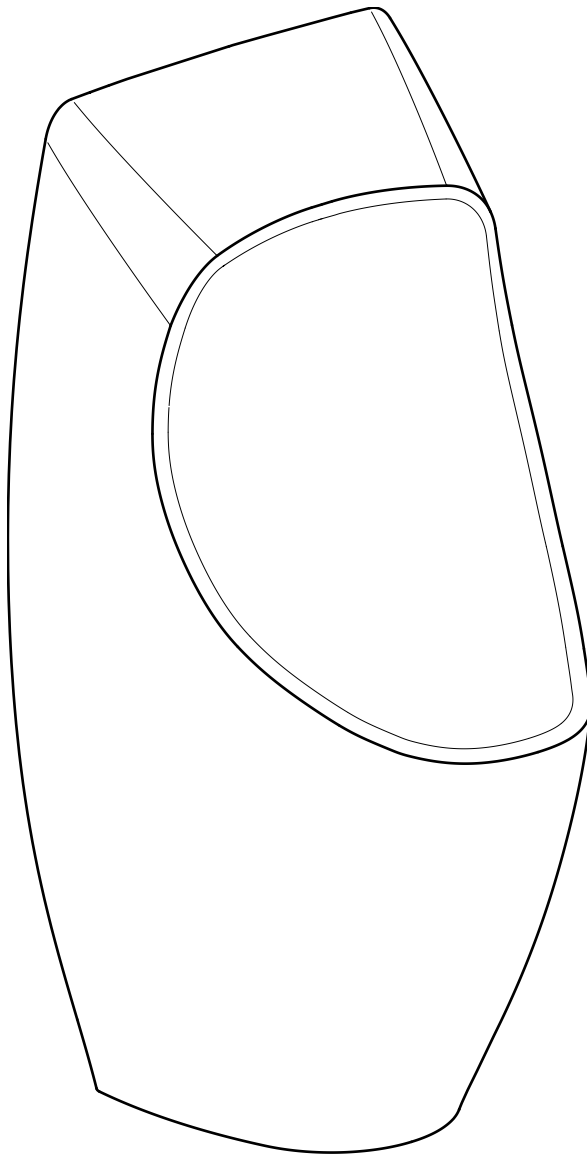

Installation instruction
Installationsanleitung
Instruction de l'installation
Instrucción de instalación
Instrução de instalação
Istruzioni per l'installazione

URIMAT ceramic Art. 12201



1 x 23.200 / Ceramic

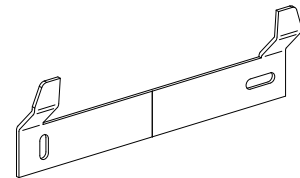

1 x 58.402 / Mounting Bracket



2 x Screw / Washer / Dowel



1 x 56.111 / Screen

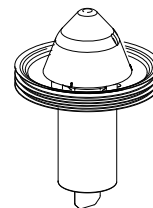

1 x 52201 / MB ActiveTrap

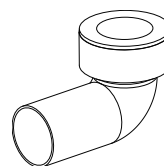

1 x 58.009 / Drainpipe DN50

Dimensioning
Abmasse
Massification

Masificación
Massificação
Massificazione

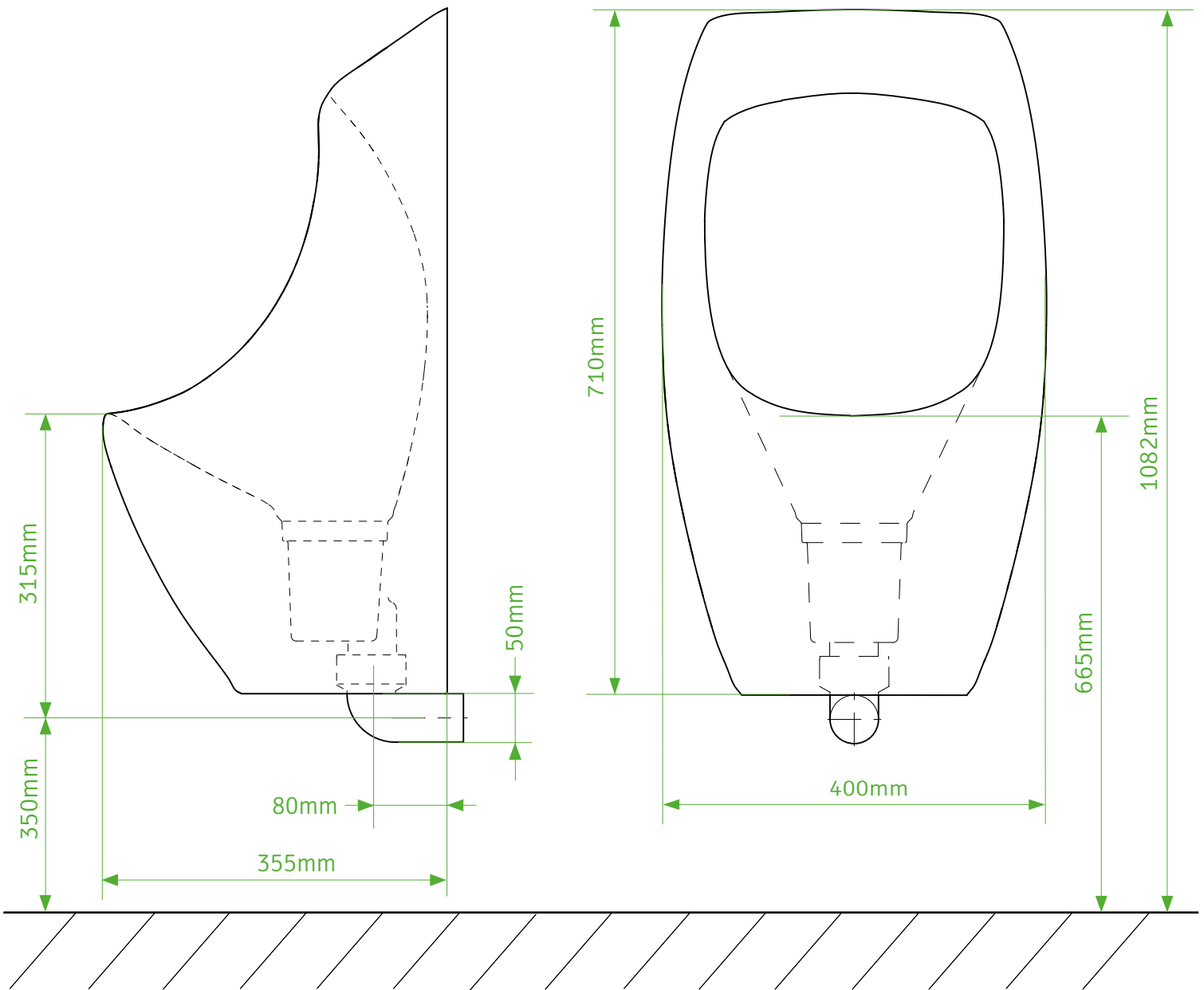

Important:

Make sure all drainpipes are professionally cleaned when replacing existing waterflushed urinals.

Wichtig:

Abwasserleitung müssen vor der Montage der URIMAT Urinale gereinigt werden. Es ist sicherzustellen, dass Uringestein und andere Ablagerungen beseitigt sind.

Important:

Les écoulements d'eau résiduelles doivent être purgés avant le montage de l'urinoir URIMAT. Il faut assurer que la pierre d'urine et d'autres dépôts sont éliminés.

Importante:

Asegúrese cuando instale los URIMAT que los desagües existentes están perfectamente limpios y totalmente exentos de obturaciones.

Importante:

Ao trocar um Urinol convencional por um URIMAT deverá ser garantida a limpeza da tubagem por pessoal especializado.

Importante:

Assicurarsi che tutte le grondaie siano pulite professionalmente in caso di sostituzione orinatoio waterflushed esistenti.

Installation
Montage
Installation

Instalación
Instrução
Installazione

1

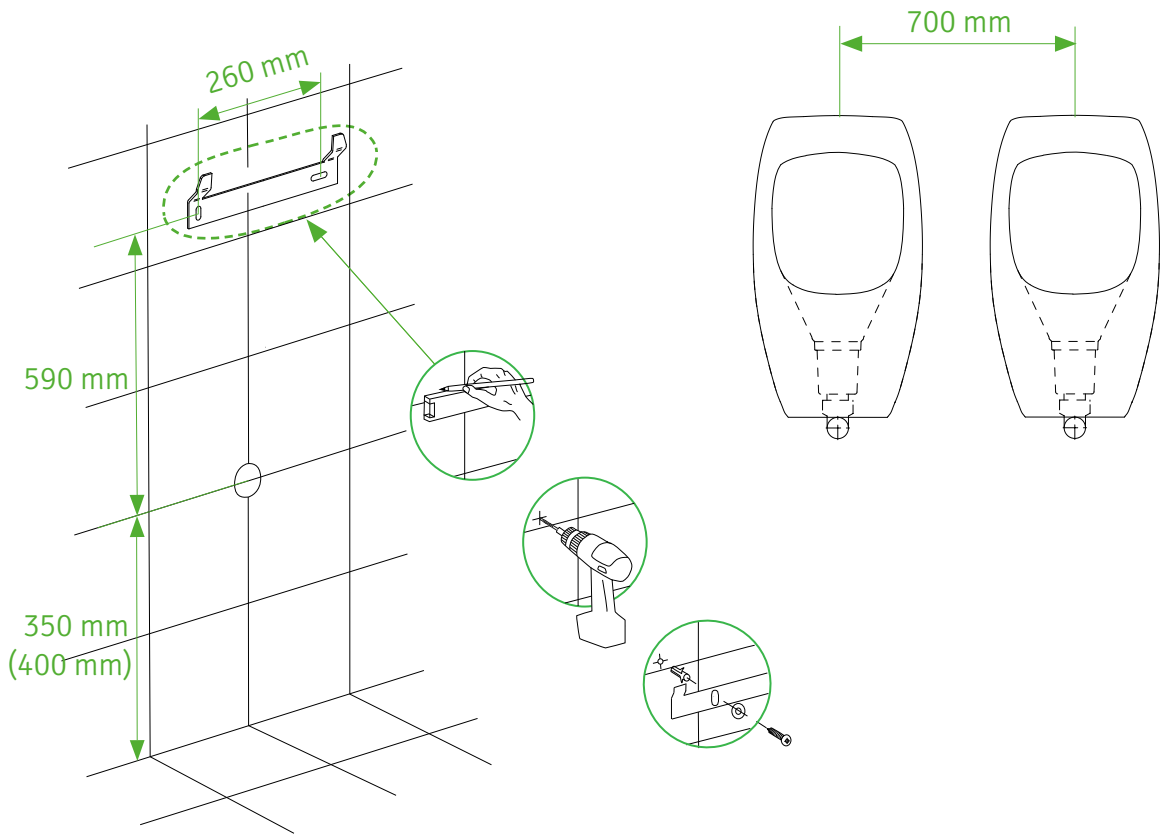

2

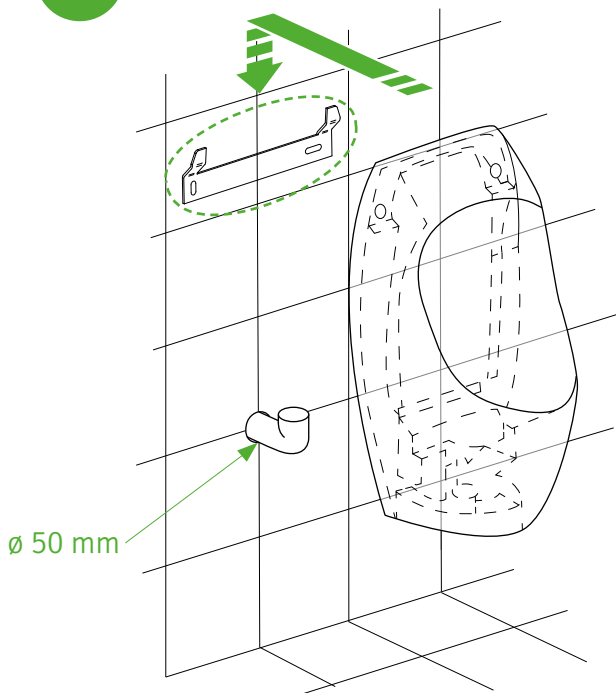

3

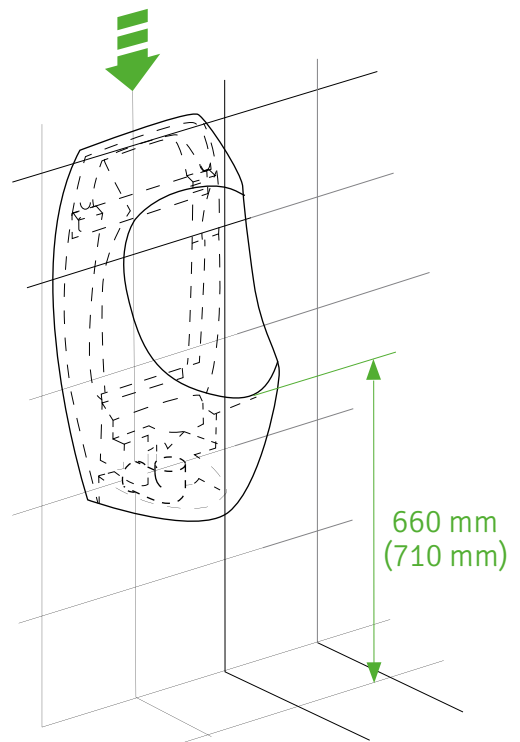



MB-ActiveTrap

Wechsel / Replacement / Scambio
 Cambio / Échange / Câmbio



New



50% used



Change!

