



# FX-M WASH PLACE UNIT Clean & Towel

## FX-M washing area unit "water-soap-paper towel dispenser"

- for wall mounting
- Contactless opto-electronically controlled
- for hot and cold water connections  
Including thermostat for mounting on the angle valve with installation kit for premixed hot water
- Soap pump for liquid soap and hand dryer integrated in the set
- Illumination of the pictograms above the respective sensor
- The position of the sensor and the lighting of the
- The start of hand washing are displayed to the user
- The pictogram of the active function lights up brightly
- Housing made of high-quality powder-coated stainless steel, white
- mirrored door
- Left door hinge and cylinder lock
- Mirror made of laminated safety glass
- Illuminated icon bar made of ESG glass
- Soap tank not included

Dimensions: 600 x 900 x 205 mm (W x H x D)  
**Article Number: 85 45**

### Technical specifications

|                                 |  |
|---------------------------------|--|
| Minimum flow:                   | Pressure 1.0 bar                             |
| Volume of water flow:           | 6 l / min, 3 bar flow pressure 230           |
| Power supply:                   | V AC, 50/60 Hz                               |
| Total output:                   | 60 W   |
| Degree of protection:           | IP20   |
| Soap pump flow time:            | 0.1-25.5 s                                   |
| Paper towel dispenser capacity: | 300 to 400 pieces<br>(HS format with Z-fold) |

### Recommended sink for FX-M washbasin unit

The Quadro-FX single washbasin is suitable for single-user installation:

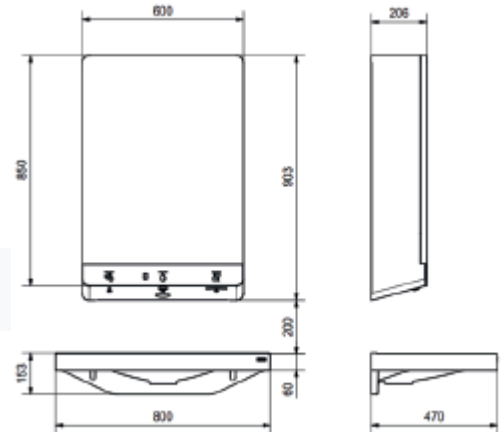
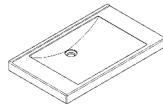

As a tailor-made washbasin solution for row installation  
 From our Varius range, choose the ETON trough with a back wall.  
 The washbasins are made of Miranit, a synthetic resin-bonded mineral material.